

**STANDARDS COMMITTEE
FOR HI-LOK® PRODUCTS**
2600 SKYPARK DRIVE, TORRANCE, CALIFORNIA 90509

HI-SHEAR CORPORATION, U.S.A. (Patent Holder) U.S. Federal Code I.D. No. 73197	HI-SHEAR FASTENERS EUROPE LTD. U.K. (Licensee)
Division of Hi-Shear Industries Inc. U.S.A. (Licensee)	Division of Hi-Shear Industries Inc. U.S.A. (Licensee—EEC Countries)
AIA INDUSTRIES CO. INC. (Licensee) U.S. Federal Code I.D. No. 06725	KAMAZ-WERKE Germany (Licensee—EEC Countries)
DEUTSCH FASTENER CO., INC. (Licensee) U.S. Federal Code I.D. No. 87928	Rudolph Kammann GmbH & Co. (Licensee—EEC Countries)
SPI TECHNOLOGIES, U.S.A. (Licensee) U.S. Federal Code I.D. No. 86078	ST. CHAMOND (FRANCE), S.A. France (Licensee—EEC Countries)
VOI-SHAN, Division of VSI Corp., U.S.A. (Licensee) U.S. Federal Code I.D. No. 92215	SIMMONDS S.A. France (Licensee—EEC Countries)
WEST COAST AEROSPACE INC., U.S.A. (Licensee) U.S. Federal Code I.D. No. 60516	(Licensee)
(Pat. & Steel Collars)	TOKYO SCREW COMPANY, Japan (Licensee—Japan)

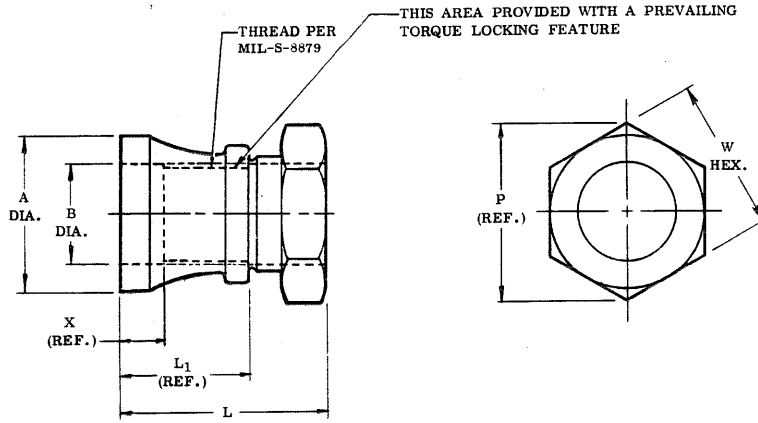

DASH NO.	PIN NOM. DIA.	THREAD	A DIA.	B DIA.		L	L1 (REF.)			P (REF.)		W HEX.	X (REF.)	L1	UTS LBS. MIN.	TORQUE OFF IN. LBS.
-6	7/32	10-32UNJF-3B	.332 .328	.227 .223		.470 .450	.290			.380		.346 .332	.122		2,500	25-35
-8	9/32	1/4-28UNJF-3B	.427 .423	.290 .286		.565 .545	.355			.484		.440 .425	.127		4,300	60-80
-10	11/32	5/16-24UNJF-3B	.560 .554	.356 .350		.685 .665	.445			.624		.565 .550	.137		6,300	130-160
-12	13/32	3/8-24UNJF-3B	.683 .675	.419 .413		.755 .735	.485			.763		.690 .675	.137		8,700	200-240
-14	15/32	7/16-20UNJF-3B	.748 .740	.481 .475		.875 .855	.575			.840		.753 .736	.152		12,100	270-330
-16	17/32	1/2-20UNJF-3B	.870 .860	.543 .537		.955 .935	.625			.970		.878 .861	.152		15,300	370-430
-18	19/32	9/16-18UNJF-3B	.925 .915	.613 .607		1.060 1.040	.700			1.120		.941 .924	.165		20,500	500-575
-20	21/32	5/8-18UNJF-3B	1.000 .990	.678 .672		1.150 1.130	.755			1.120		1.003 .986	.165		25,700	625-700
-24	23/32	3/4-16UNJF-3B	1.185 1.175	.803 .797		1.400 1.380	.965			1.240		1.128 1.110	.176		37,300	900-1000

NOTES: 1. Go thread gage penetration shall be 3/4 of one revolution minimum.
2. Dimensions apply after finish.

MATERIAL: A-286 high temperature alloy per AMS5731, AMS5734 or AMS5736.

FINISH: HL197-() = Silver plate per AMS2410 and cetyl alcohol lube per Hi-Shear Spec. 305.
HL197D-() = Solid film lube per MIL-L-8937.
HL197DJ-() = Solid film lube per MIL-L-8937 plus green identification on body of collar.
HL197DU-() = Solid film lube per MIL-L-8937 plus yellow MIL-P-23377 identification on body of collar.
HL197EG-() = Solid film lube per "Everlube" 820.
HL197K-() = Solid film lubricant per "Lubeco" 905.
HL197KG-() = Cadmium plate per QQ-P-416, Type II, Class 2, color green, and cetyl alcohol lube per Hi-Shear Spec. 305.
HL197PB-() = Cadmium plate per QQ-P-416, Type II, Class 2, and cetyl alcohol lube per Hi-Shear Spec. 305.
HL197TF-() = Hi-Kote 2 solid film lube per Hi-Shear Spec. 292.
HL197V-() = Solid film lubricant per "Lubeco" 2123.

SPECIFICATION: Hi-Lok Product Specification 345.

CODE: Dash number indicates nominal thread size in 1/32nds.
See "Finish" note for explanation of other code letters.

EXAMPLE: HL197K-8 = 1/4-28 Hi-Lok oversize collar, finish is "Lubeco" 905.

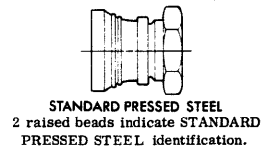
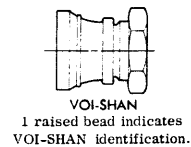

Patented internationally. "Hi-Lok" and "HL" are internationally registered trademarks of Hi-Shear Corporation.

DRAWN	DATE	BY	TITLE	DRAWING NUMBER
	3-31-66	Brlj		
CHECKED	3-31-66	Miller	hi-Lok® COLLAR A-286 HIGH TEMPERATURE ALLOY 1/16" GRIP VARIATION - SHEAR APPLICATION FOR USE ON 1/32" OVERSIZE HI-LOK PINS	HL197
REVISION	5-26-89	D. P. S.		