

hi-shear
CORPORATION

2600 Skypark Drive
Torrance, California 90509 U.S.A.
Telephone (310) 326-8110
FAX (310) 784-4144

"CAGE" = Commercial An... it Entity

HI-SHEAR CORPORATION, U.S.A. (Patent Holder) CAGE No. 73107
Division of Hi-Shear Industries, Inc., U.S.A.
AIR INDUSTRIES CO., INC. (Licensee - U.S. & Canada) CAGE No. 06725
SPS TECHNOLOGIES, U.S.A. (Licensee) CAGE No. 56678
HI-SHEAR FASTENERS EUROPE LTD. U.K. (Licensee) CAGE No. OL888
Division of Hi-Shear Industries, Inc., U.S.A.

HUCK INTERNATIONAL GmbH & Co. Germany (Licensee - EEC Countries)
SIMMONDS S.A. France (Licensee - EEC Countries - Collars)
SL-CHAMOND GRANAT S.A. France (Licensee - EEC Countries)
TOKYO SCREW COMPANY, Japan (Licensee - Japan)
941103

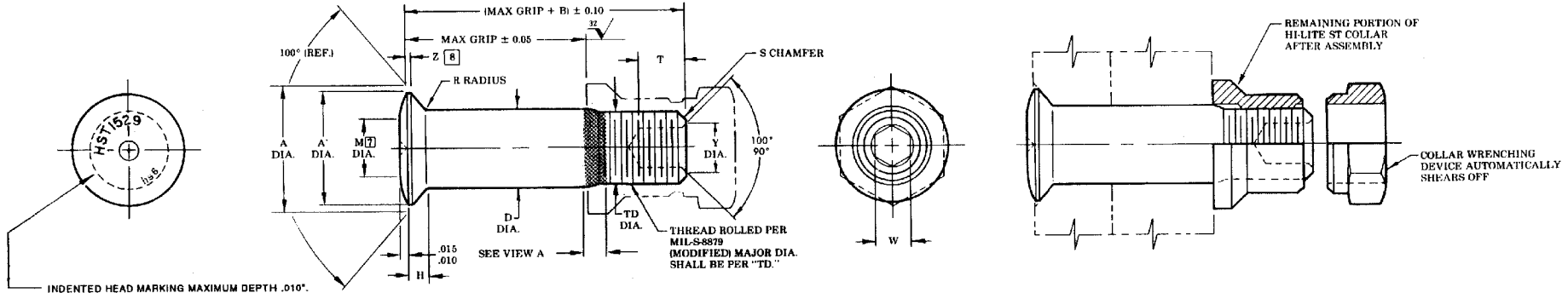

INDENTED HEAD MARKING MAXIMUM DEPTH .010".
"hs" INDICATES HI-SHEAR TRADEMARK. THE NUMBER(S) FOLLOWING THE TRADEMARK INDICATE FIRST DASH NUMBER. ARRANGEMENT OPTIONAL. INDENTATION IS .050-.060 DIAMETER x .020-.030 DEPTH.

HI-LITE™ ST™ PIN

HI-LITE™ ST™ PIN AND COLLAR AFTER ASSEMBLY

FIRST DASH NO.	NOM. DIA.	A DIA.	A' DIA.	B REF.	D DIA BEFORE FINISH	TD DIA.	F	H	K MAX	M DIA. FLAT	R RAD.	Z MAX.	S CHAMFER REF.	THREAD	SOCKET			DOUBLE SHEAR POUNDS	TENSION POUNDS MINIMUM
															W HEX.	T DEPTH	Y DIA.		
5	5/32	.2822 .2874	.285 .273	.312	.1694 .1690	.1595 .1570	.004	.0515 .0495	.013	.140 .120	.025 .015	.010	1/32" x 3/32"	8-32UNJC-3A Modified	.0801 .0791	.100 .080	.090 .075	4,600 4,010	1,730
6	3/16	.3538 .3486	.346 .334	.325	.1954 .1950	.1840 .1810	.005	.0664 .0643	.016	.155 .135	.030 .020	.015	1/32" x 3/32"	10-32UNJF-3A Modified	.0806 .0791	.100 .080	.119 .104	6,200 5,380	2,590
8	1/4	.4732 .4682	.466 .454	.395	.2554 .2550	.2440 .2410	.006	.0814 .0893	.021	.200 .180	.030 .020	.015	1/32" x 3/32"	1/4-28UNJF-3A Modified	.0967 .0947	.110 .090	.142 .122	10,600 9,300	4,760
10	5/16	.5619 .5569	.555 .542	.500	.3179 .3175	.3060 .3020	.007	.1024 .1003	.026	.265 .245	.040 .030	.015	3/64" x 3/32"	5/16-24UNJF-3A Modified	.1295 .1270	.130 .110	.180 .160	16,800 14,800	7,100
12	3/8	.6812 .6862	.684 .672	.545	.3804 .3800	.3680 .3640	.008	.1304 .1283	.030	.325 .300	.040 .030	.015	3/64" x 3/32"	3/8-24UNJF-3A Modified	.1617 .1582	.160 .140	.217 .197	23,900 21,000	10,600
14	7/16	.8041 .7969	.797 .772	.635	.4429 .4425	.4310 .4260	.009	.1515 .1485	.035	.380 .355	.050 .040	.022	3/64" x 3/32"	7/16-20UNJF-3A Modified	.1930 .1895	.190 .170	.253 .233	32,500 28,600	14,450
16	1/2	.9166 .9095	.910 .885	.685	.5054 .5050	.4930 .4880	.010	.1725 .1695	.039	.445 .415	.050 .040	.022	3/64" x 3/32"	1/2-20UNJF-3A Modified	.2242 .2207	.220 .200	.289 .269	42,400 37,300	19,550
18	9/16	1.0337 1.0266	1.027 1.002	.770	.5674 .5670	.5550 .5500	.010	.1956 .1927	.039	.505 .475	.050 .040	.022	1/16" x 3/32"	9/16-18UNJF-3A Modified	.2555 .2520	.260 .240	.326 .306	53,700 47,200	24,700
20	5/8	1.1230 1.1158	1.116 1.091	.825	.6299 .6295	.6180 .6120	.010	.2069 .2039	.044	.565 .535	.050 .040	.022	1/16" x 3/32"	5/8-18UNJF-3A Modified	.2555 .2520	.260 .240	.326 .306	66,300 58,300	29,600

SEE COLLAR STANDARDS FOR COLLAR STRENGTHS. LOWER STRENGTH (PIN OR COLLAR) DETERMINES SYSTEM STRENGTH.

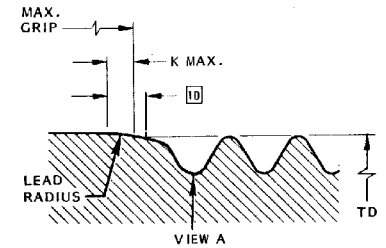

GENERAL NOTES:

- Head edge out of roundness shall not exceed "F".
- Concentricity: Conical surface of head to "D" diameter within .005 FIR.
- "H" is dimensioned from maximum "D" diameter.
- Dimensions to be met after finish, except as noted.
- Surface texture per ANSI B46.1.
- Hole preparation per NAS618.
- Flat permissible within "M" diameter.
- Curved or flat edge manufacturer's option.
- Use HST1529 for oversize replacement.
- Lead radius must be tangent to "D" diameter within "K" distance and be continuous within this area.
- "D" diameter may increase by .001 after application of finish.

CODE:

First dash number indicates nominal diameter in 1/32nds.
Second dash number indicates maximum grip in 1/16ths.
See "Finish" note for explanation of code letters.

HOW TO ORDER EXAMPLES:

Pin Part Number Only
HST1529DL-8-8
8/16 or 1/2 Maximum Grip Length
8/32 or 1/4 Nominal Diameter Pin
Pin Part Number

MATERIAL:

6Al-4V titanium alloy per Spec. AMS4928 or AMS4967.

HEAT TREAT:

95,000 psi shear minimum.

FINISH:

HST1529DL-(-) = Kalgard FA or EM620C solid film lube per MIL-L-46010, Type I and cetyl alcohol lube per Hi-Shear Spec. 305.
HST1529AP-(-) = Hi-Kote 1 aluminum coating per Hi-Shear Spec. 294, and cetyl alcohol lube per Hi-Shear Spec. 305.

SPECIFICATION:

Hi-Lite Product Specification 380.

U.S. Patents 4,326,825; 4,485,510 and 4,957,401.
Other U.S. and foreign patents pending.
"Hi-Lite" is a registered trademark and "Hi-Lite ST" is a trademark of Hi-Shear Corporation.

DRAWN	DATE	TITLE
J.F.Obispo	4-17-95	HI-LITE® ST™ PIN 100° FLUSH CROWN (MS20426) HEAD TITANIUM SPECIAL THREAD AND SHANK 1/16" GRIP VARIATION
APPROVED	DATE	DRAWING NUMBER
E.E.B.	2-15-74	HST1529
REVISION	DATE	

HST1529